

7

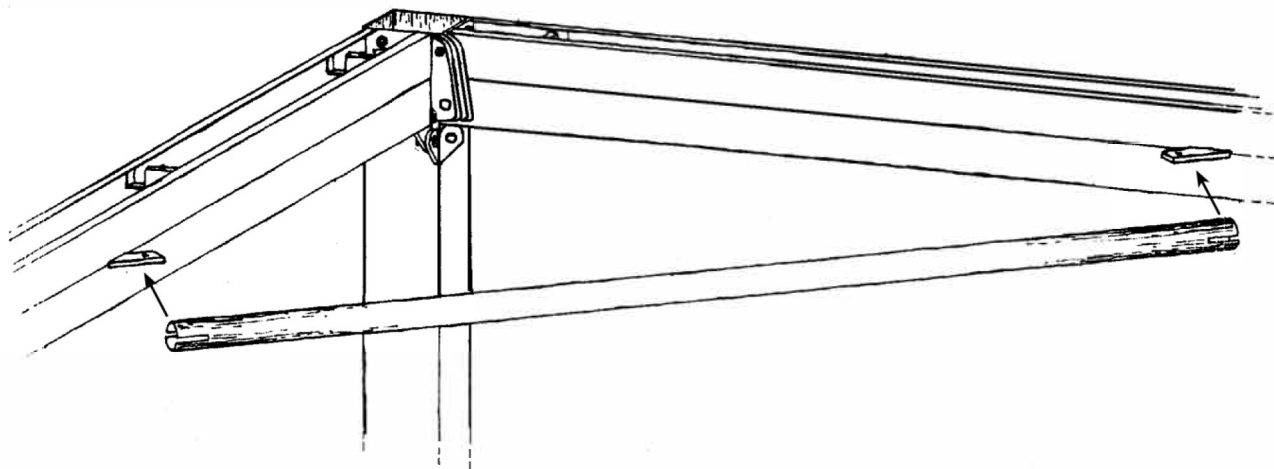

**Montare le controventature angolari (tubi angolari) sulle apposite piastre.**  
*Assemble the corner-bracing tubes to proper plates.*

8

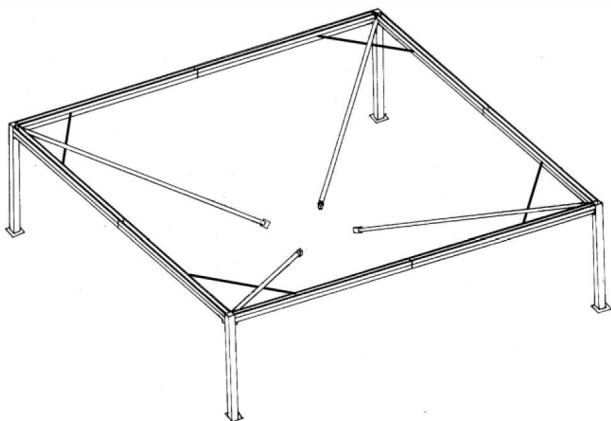

**Sollevarle le traverse da un lato e fissarle alle piastre d'angolo con i bulloni.**  
*Uplift and fix with proper bolts the inclined rafters to the corner joints.*

9

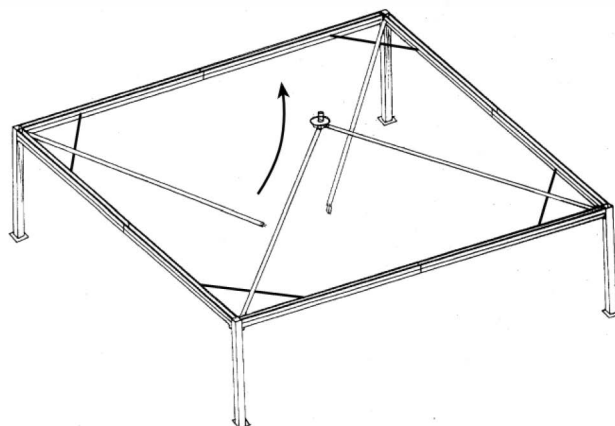

**Alzare le traverse e bullonarle al raccordo centrale.**  
*Uplift the inclined rafters and secure with proper bolts to the central joint*

10

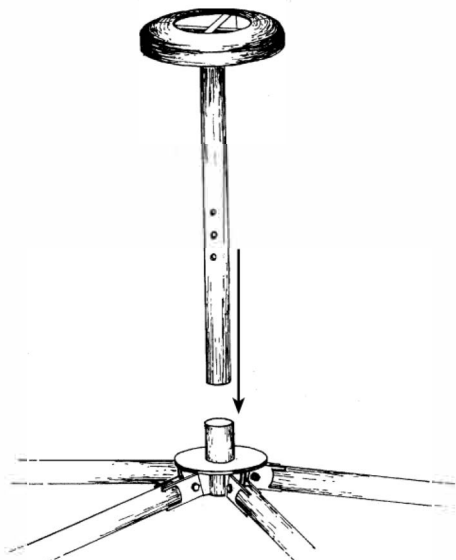

**Inserire il puntone spingitelo nel raccordo centrale.**  
*Insert the pvc-fabric lifting rafter into central joint*

11

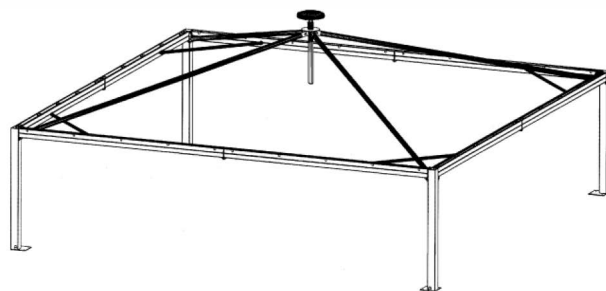

12

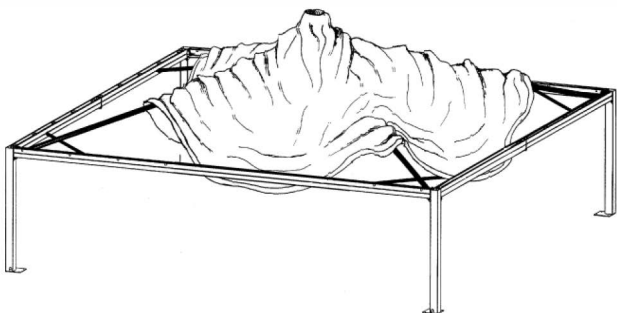

**Adagiare il telo sopra la struttura facendo attenzione che sia perfettamente centrato.**  
*Lay pvc-fabric over the upper structure, positioning it accurately*

13

**Vista dall'esterno**  
*Outside view*

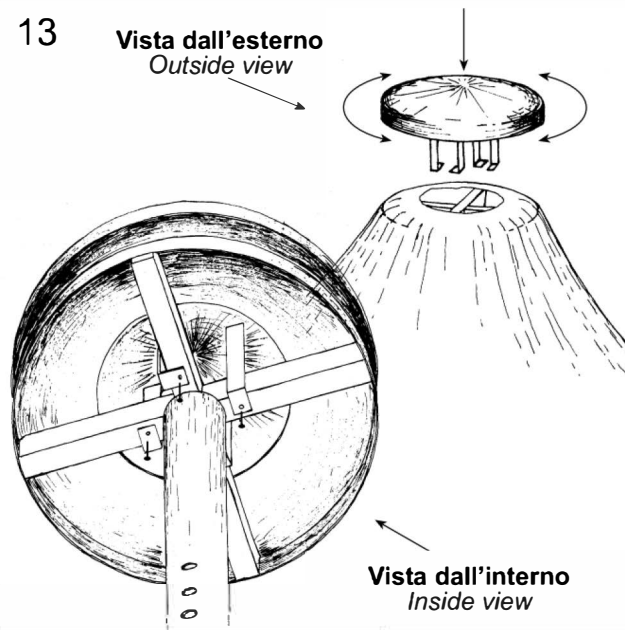

**Vista dall'interno**  
*Inside view*

14

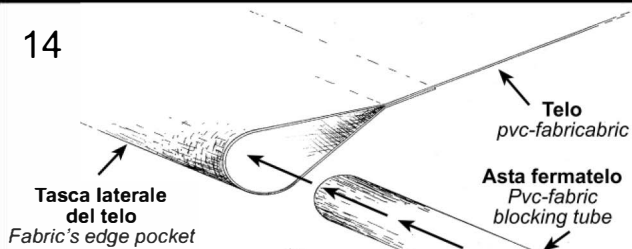

**Inserire le aste fermatelo nella tasca laterale. Spingere le aste sotto la scanatura della trave e ruotare gli appositi tasselli rettangolari.**  
*Slide pvc-fabric blocking tube into pvc-fabric edge pocket. Place the tube into the horizontal beam's fluting and rotate appropriate metallic rectangular wedges against them*

**Sezione trave perimetrale**  
*Perimetrical beam section*

**Tassello rettangolare da ruotare per bloccaggio asta fermatelo**  
*Rectangular wedge to be rotated so to fix pvc-fabric blocking tube*

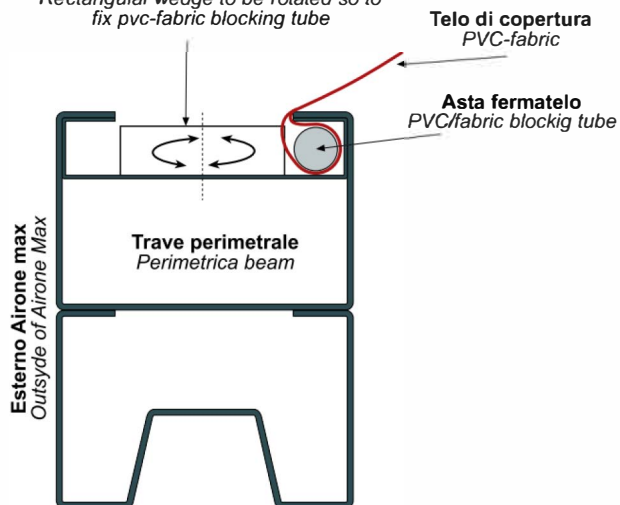

**Esterno Airone max**  
*Outside of Airone Max*

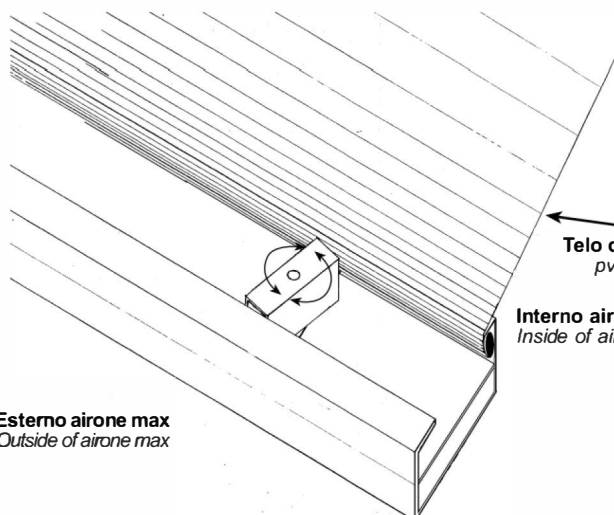

**Esterno airone max**  
*Outside of airone max*

**Telo di copertura**  
*pvc-roofing*

**Interno airone max**  
*Inside of airone max*

15

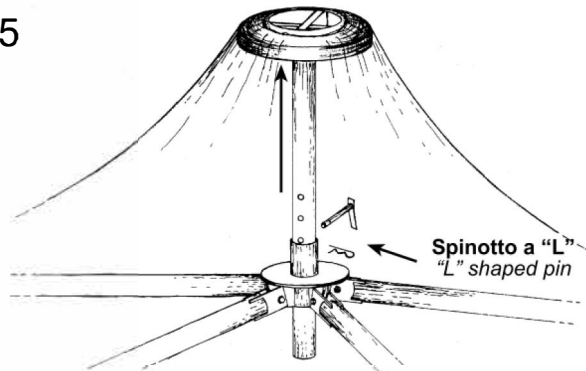

**Spingere il puntone centrale con un martinetto idraulico (tipo camion) verso l'alto, fino a quando il telo risulterà in tensione. Inserire lo spinotto ad "L" nel foro del puntone spingitelo immediatamente superiore al raccordo centrale delle traverse.**

*Lift upwards with an hydraulic jack (truck type) the central rafter, so to reach the right tension of the pvc-fabric roofing insert "L" shaped pin into proper hole located on the central rafter, slightly above the upper side of the central joint*

16

